



Community Development Department
BUILDING & SAFETY DIVISION

100 Civic Plaza, Dublin, CA 94568 • Ph: (925) 833-6620 • www.dublin.ca.gov

Residential Water Heaters - Permit and Inspection

Purpose

A permit is required for all water heater installations, including replacement units. Permits can be issued over the counter for replacement only.

Installation

Water heaters shall be installed as per the manufacturer's installation instructions and current California Plumbing Code.

Requirements

A. Submittal Requirements

Completed permit application and energy report.

[Permit Application Form](#)

[Residential Water Heater Alteration Energy Form](#)

B. Application and Plan Review

Permit applications utilizing the City's standardized Energy form are processed over the counter and can be submitted to the Building & Safety Division in person at 100 Civic Plaza, Dublin CA 94568.

Permit applications may also be submitted electronically through: permits@dublin.ca.gov. Refer to the [Online Residential Permits Handout](#) for the permitting process.

C. Inspection

The inspector will be looking for the following minimum requirements: (Refer to the illustration for itemized references)

1. **Elevated Platform:** Gas fired water heaters located in a garage shall be installed so that burners and burner-ignition devices are located not less than 18 inches above the floor unless listed as flammable vapor ignition resistant. (CPC 507.13)
2. **Seismic Bracing:** In order to prevent the water heater from toppling over during an earthquake, it must be secured to the wall in an approved matter. (CPC 507.2)
 - Two straps required.
 - Strapping must be located at points within the upper one-third and lower one-third of the

water heater and must wrap completely around water heater and back to wall.

- Lower strap must be at least 4-inches above the controls.
 - The third strap is required for water heaters exceeding 52-gallons and the ends of all straps must be secured to a stud with a minimum 1/4-inch x 3-inches lag bolt with a washer.
 - (Please note that plumbing tape is not permitted as strapping material).
3. **Appliance Vent:** That portion of the venting system which penetrates the ceiling floor, attic or roof systems must be of type B, BW, type L, or other listed assembly approved by the Building Official. The appliance vent shall extend in a generally vertical direction with offsets exceeding 45°
 4. **Vent Connector:** That portion of the appliance vent, which is within the same room as the appliance. Vent sections must have a minimum rise of 1/4-inch per foot. Clearance from the vent connector to any combustible construction must be at least 6-inches for single wall pipe and 1-inch for double wall pipe.
 5. **Clearance of Combustibles:** The clearance from the appliance vent to any combustible construction must be at least 1-inch. In order to maintain clearances from combustible insulation in attics, a metal sleeve shall be provided around the vent pipe, extending 6-inches above insulation and maintaining a minimum of 1-inch around vent. (CPC Table 509.7.3.4)
 6. **Vent termination:** Vents must be extended above the roof surface a minimum of 12-inches and terminated in an approved vent cap. The minimum total height of the venting system is 5-feet from vent collar to termination. Termination must be a minimum of 4-feet from any opening into the building when terminating through the wall. (CPC 509.6 & Table 509.8.1 509.6.1)
 7. **Temperature & Pressure Relief Valve & Drain Line:** All storage type water heaters must be equipped with a listed temperature and

pressure relief valve and drain line. The drain line should be equal to the outlet size, but in no case be less than 3/4-inch copper or galvanized pipe, and must extend from the valve to the outside of the building. The end of the pipe should not be more than 24-inches or less than 6-inches above the ground and point downward. If you cannot drain to the outside, other locations for termination shall be approved by the Building Official. (CPC 504.6 & 608.5)

8. **Combustion Air:** Combustion air shall be provided in accordance with CPC Section 506.
9. **Gas Connection:** The gas supply must have a shut-off valve adjacent to the water heater. An approved flex connector may be used for the final connection to the water heater. Maximum length for the flex connector is 3-feet. A shut off valve must be located ahead of the flex connector and before the sediment trap (drip leg) per manufactures instructions. (CPC 1212.5.3)
10. **Noncombustible Collar:** A metal collar shall be placed against the ceiling to seal the gap between the sheetrock and the vent.
11. **Pipe Insulation:** The first 5 feet minimum of both cold and hot water inlet and outlet piping must be insulated.
12. **Pipe Bollard:** If the water heater is located in the path of travel of a vehicle, a protective 3-inches pipe bollard may be required to be installed so as to protect the water heater from damage. Pipe is to be 3-feet above floor and set into a 2-foot deep concrete foundation and filled with mortar (new construction only).
13. **Excessive Water Pressure:** Where static water pressure in the water supply piping is in excess of 80 pounds per square inch, an approved type pressure regulator preceded by an adequate strainer shall be installed and the static pressure reduced to 80 pound per square inch or less. Any water system provided with a check valve, backflow preventer or any other normally closed device. The water system shall have an approved, listed and adequately sized expansion tank or other approved device having a similar function to control thermal expansion. (CPC 608)
14. **Bonding of Piping:** Water and gas pipes shall be bonded. (CEC 250.104)

For additional information regarding this permit process, please consult the [Building & Safety](#) website or contact the office at (925) 833-6620.

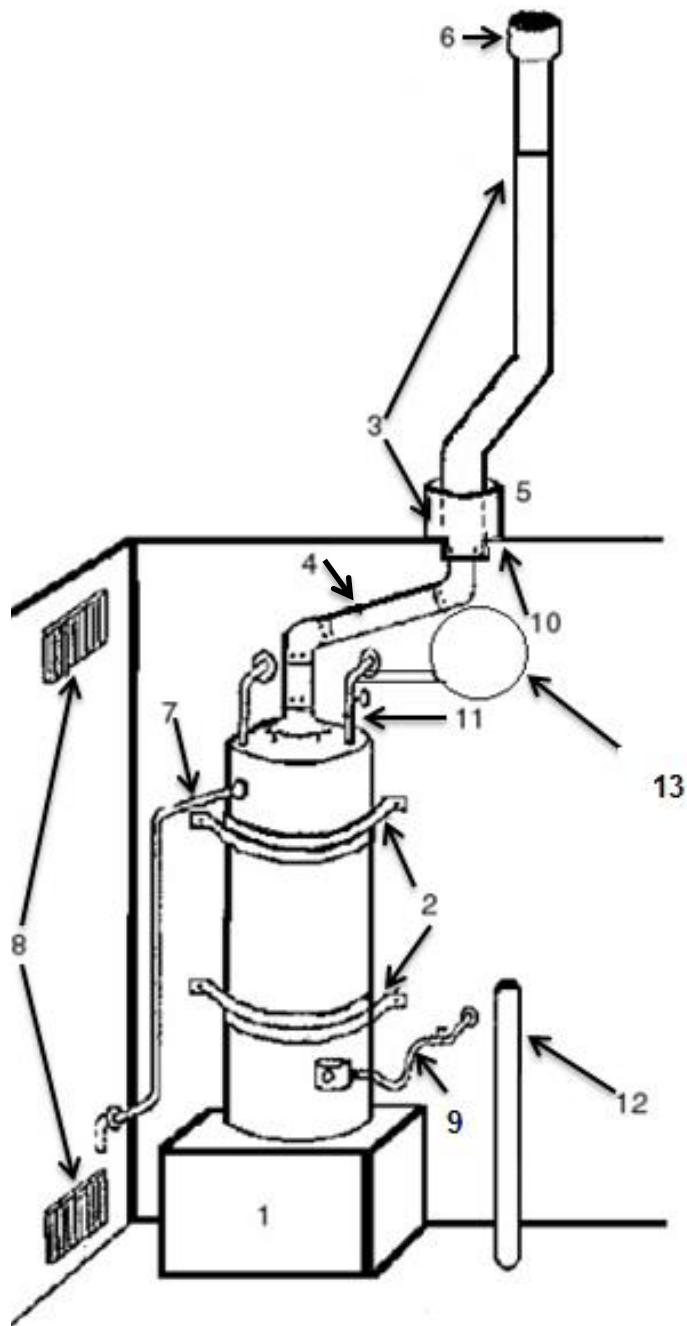

Typical Garage Installation